

Paper Id:

2	3	1	8	4	0
---	---	---	---	---	---

Roll No.

--	--	--	--	--	--	--	--	--	--	--	--	--	--	--	--	--	--	--	--

B.TECH.
(SEM V)THEORY EXAMINATION 2022-23
STRUCTURAL ANALYSIS

Time: 3 Hours

Total Marks: 100

Note: Attempt all Sections. If you require any missing data, then choose suitably.

SECTION A

1. Attempt *all* questions in brief. 2x10 = 20

- (a) Explain load transfer mechanisms for portal frames.
- (b) Classify different types of trusses based on static determinacy.
- (c) What is compound truss?
- (d) List various methods for the analysis of trusses.
- (e) State Maxwell reciprocal theorem.
- (f) Write down the applications of Castigliano's first theorem.
- (g) What do you understand by ILD?
- (h) Where do you get rolling loads in practice?
- (i) Differentiate between Beam and Arch.
- (j) Which of the two arches, viz. circular and parabolic is preferable to carry a uniformly distributed load? Why?

SECTION B

2. Attempt any *three* of the following; 10x3 = 30

- (a) Differentiate the statically determinate structures and statically indeterminate structures?
- (b) Determine the forces in members by using method of tension coefficient.

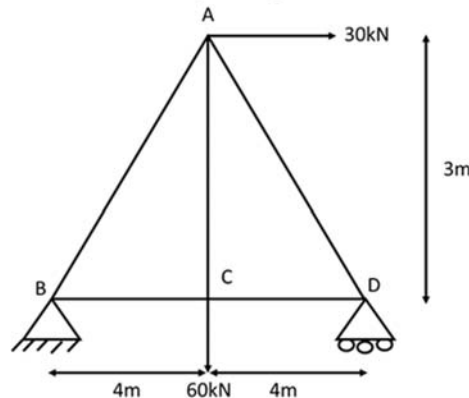

- (c) State and write down the application of Maxwell's reciprocal theorem.
- (d) For the given beam, plot influence line diagram for shear at C.

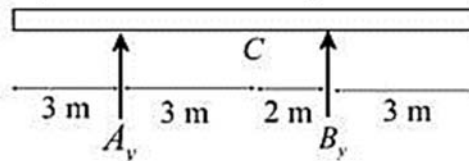

- (e) A three hinged parabolic arch hinged at the supports and at the crown has a span of 24 m and a central rise of 4 m. It carries a concentrated load of 50 kN at 18 m from left support and a uniformly distributed load of 30kN/m over the left-half portion. Determine the moment, thrust and radial shear at a section 6 m from the left support.

SECTION C

3. Attempt any *one* part of the following:

10x1 = 10

- (a) A cable of span 120 m and dip 10 m carries a load of 6 kN/m of horizontal span. Find the maximum tension in the cable and the inclination of the cable at the support. Find the forces transmitted to the supporting pier if the cable passes over smooth pulleys on top of the pier. The anchor cable is at 30° to the horizontal. Determine the maximum bending moment for the pier if the height of the pier is 15 m.
- (b) Determine the kinematic and static determinacy of the given truss.

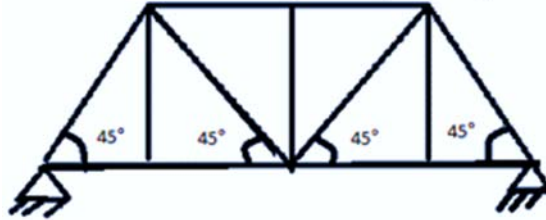

4. Attempt any *one* part of the following:

10 x1 = 10

- (a) Using method of joints, determine the forces in the members of the trusses shown.

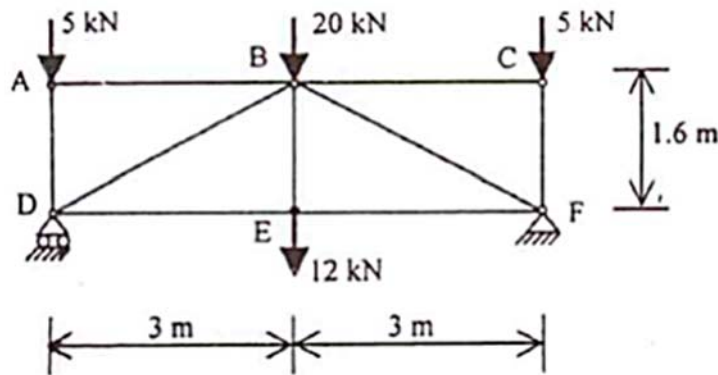

- (b) Using method of section, determine the forces in the members of the trusses shown.

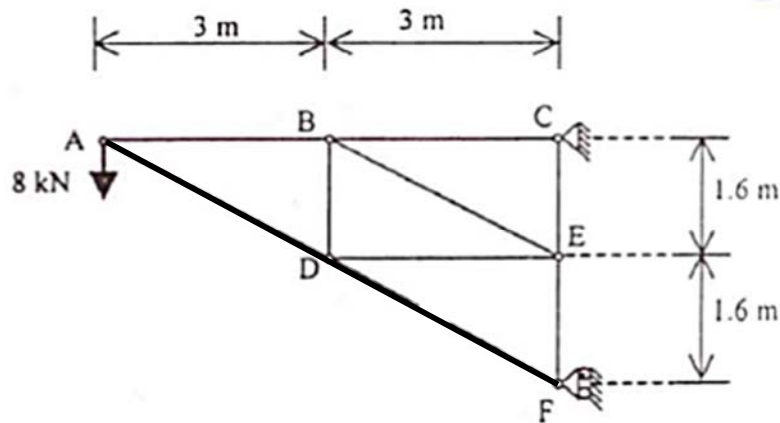

5. Attempt any *one* part of the following: 10x1 = 10

- (a) Using the unit load method, determine the vertical deflection of the free end of the cantilever beam shown in figure. For the beam $I = 10^9 \text{ mm}^4$, $E = 207 \text{ Gpa}$.

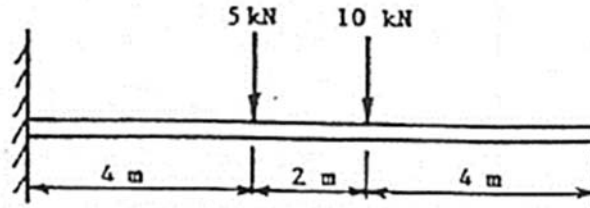

- (b) Using the conjugate beam method, determine the vertical deflection of the free end of the cantilever beam shown in figure.

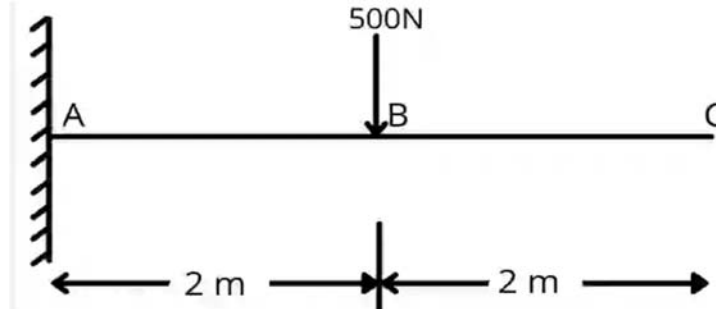

6. Attempt any *one* part of the following: 10x1 = 10

- (a) The given figure of beams, construct:
 i) the influence line for vertical reaction at A and B.
 ii) the influence line for shear at C.
 iii) the influence line for bending moment at C.

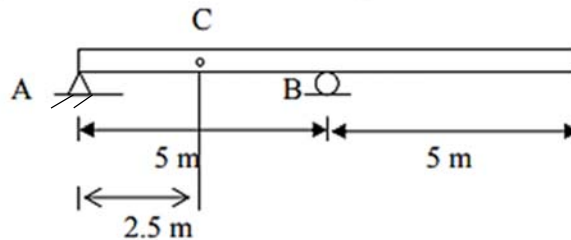

- (b) Determine maximum moment at point X on the deck due to the wheel loads of the moving car which is moving from A to B.

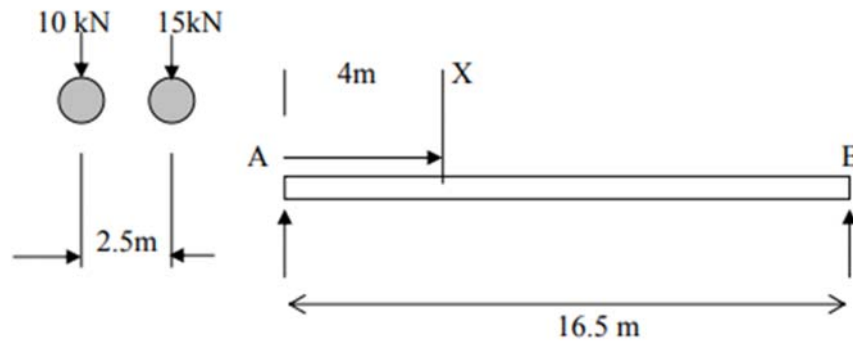

7. Attempt any *one* part of the following:

10*1 = 10

- (a) A three hinged parabolic arch of span 30 m and central rise of 5m. it is subjected to a concentrated load of 40kN at 6m span. Calculate the normal thrust, shear force and bending moment at 6m from the left support.

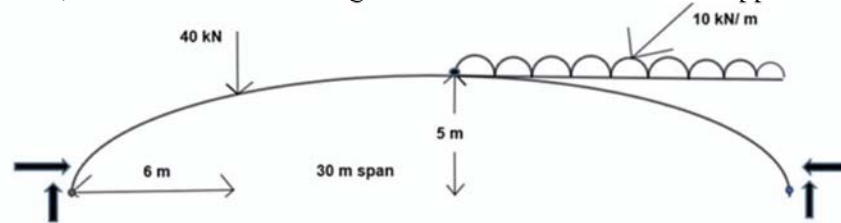

- (b) Classify the arches based on materials, shapes and structural systems with the help of neat sketch. Also, distinguish between two hinged and three hinged arches.

QP23DP1_311

| 18-01-2023 13:29:45 | 115.243.172.58